

Welcome to the **200 Plus Quick Start Guide**. These simple instructions will help you accomplish basic tasks on your Strand Lighting 200 Plus Console. Working in *Two Scene Mode*, *Single Scene Mode* and *Submaster Mode* are covered here (as well as a layout of the programming interface) and will help boost you toward the goal of mastering your Strand Lighting 200 Plus Console.

## Two Scene Mode

### Description

Separate scenes are set up on the **Preset A** and **Preset B** faders. The **A Master** and **B Master** faders are used to cross fade between the two different scenes.

### How to get into Two Scene Mode

- Press the TWO SCENE button once. It will turn **yellow**
- Press the TWO SCENE button a second time. It will now turn **dark green**.
- You are now in TWO SCENE mode.

### Example of operation of TWO SCENE mode with manual fading

- 1) Make sure the PRESET A MASTER and the PRESET B MASTER faders are at the top.
- 2) Set PRESET A fader [1] to 100%.
- 3) Set PRESET B fader [10] to 100%
- 4) Move the PRESET MASTER FADERS from the top to the bottom

***Congratulations you have just run your first cue!***

***For additional tips on Two Scene Mode and how to fade between scenes using a set time. Check out timed fades on page 14 of the manual.***

# 200 Plus Quick Start Guide

---

## Single Scene Mode

### How to get into Single Scene Mode

- Press the SINGLE SCENE button once. It will turn **yellow**
- Press the SINGLE SCENE button a second time. It will now turn **dark green**.

#### Description

You are able to cross fade between 48 channels (24 channels on the 12/24 model). This is completed by activating the **next** button and then using the **A Store and B Store** buttons to hold scenes set on either the **Preset A** faders or **Preset B** faders.

- You are now in SINGLE SCENE mode.

### Example of operation of SINGLE SCENE mode with manual fading

- 1) Make sure the PRESET A MASTER and the PRESET B MASTER faders are at the top. This will cross fade any channels on PRESET A to 100%.
- 2) Set PRESET A faders [1], [2] & [3] to 100%.
- 3) Press the NEXT button.
- 4) Press the **A STORE** button. It will turn **red**.
- 5) Reset PRESET A faders [1], [2] & [3] to 0%.
- 6) Set PRESET B faders [4], [5] & [6] to 100%.
- 7) Move the PRESET MASTER FADERS from the top to the bottom.
  - a. You can then also store the new scene if required. To do this, follow the next steps.
- 8) Press the **B STORE** button. It will turn **red**.
- 9) Reset PRESET B faders [4], [5] & [6] to 0%.
- 10) Set PRESET A faders [7], [8] & [9] to 100%.
- 11) Move the PRESET MASTER FADERS from the bottom to the top.

Press **NEXT** to deactivate the holding feature after moving the preset master faders.

***Congratulations you have just run three separate cues!!***

***To find out how to add set times to these fades check out page 17 in the manual.***

# 200 Plus Quick Start Guide

---

## Submaster Mode

### Description

In this mode it is possible to store groups of conventional channels and then play them back individually or sequentially.

### How to get into Single Scene

- Press the SUBMASTER Button once. It will turn **red**.

### RECORDING a Submaster example

- 1) Go into SINGLE SCENE mode
- 2) Set faders [1], [2] & [3] to 100%.
- 3) Press **RECORD**
- 4) Select Submaster 1 by pressing the flash button below fader 1. Note: available submasters will have flashing red bump buttons.
- 5) Reset faders [1], [2] & [3] to 0%.
- 6) Set faders [4], [5] & [6] to 100%.
- 7) Press **RECORD**
- 8) Select Submaster 2 by pressing the flash button below fader 2.

***Congratulations, you have just recorded two submasters.***

### Playing back Submasters

- 1) Set all channel faders to 0%.
- 2) Press the SUBMASTER button. It will turn **red**.
- 3) Raise fader 1 and fader 2 to 100%. Channels 1-6 will rise to their recorded levels.
- 4) Reset these channels by lowering faders 1 and 2.

# 200 Plus Quick Start Guide

## Playing back Submasters sequentially

- 1) Move the Preset A Master and Preset B master faders to the bottom.
- 2) Go into **SUBMASTER** mode.
- 3) Press the **NEXT** button. This will turn **blue**.
- 4) The first submaster flash button will now be flashing **yellow**. Raise Preset A Master and the Preset B Master to the top. The first recorded submaster will now be outputting and the bump button will be a solid **yellow**.
- 5) The next submaster to output will now have a flashing **yellow** bump button. Lower the Preset A and Preset B master faders to the bottom. The second submaster will now be outputting instead of the first.

*Find more about submaster pages, playing back submasters with times manually or sequentially and also deleting single submasters, pages of submasters of all recorded submasters.*

## Programming Interface

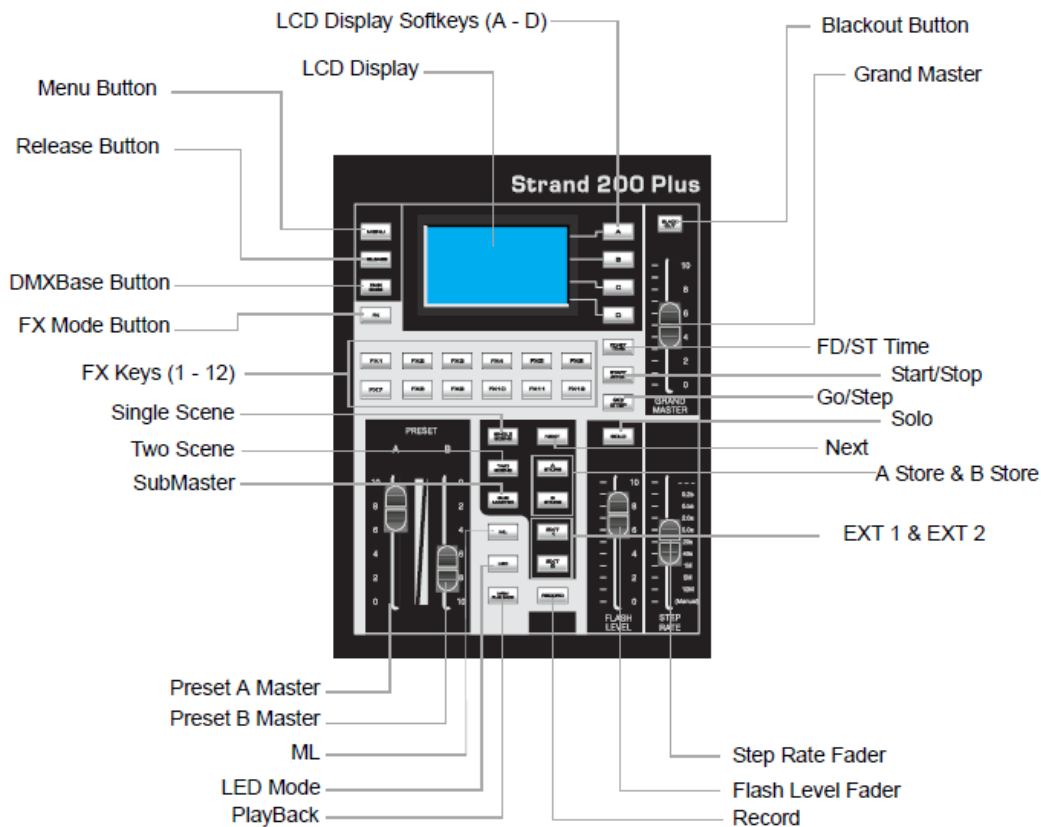

**Strand Lighting 200 Plus Programming Interface**